

FITTING INSTRUCTIONS

The Lerwick – This over door canopy has an attractive sloping tile roof in a choice of colours.

- Establish and mark on the wall, the centre line of door and desired height for the bottom of the soffit.
- Mark the centre line on the soffit of the canopy.
- Ensure the mounting surface is plumb and smooth.
- Mark out and pre-drill 3 to 9 holes (dependent on size of canopy) with 7.5mm x 100mm holes along the back flange of the canopy.
- Offer canopy to wall, matching centre point of soffit to marked centre line on the door reveal. Check the canopy is level using spirit level.
- With the canopy held in position, mark centre points of fixing holes on wall through pre - drilled holes in the flange section of canopy.
- Remove canopy from wall.
- Drill 7.5mm diameter mounting holes in wall to required depth.
- Offer canopy to the wall, ensure centre lines match and place 8mm x 100mm Concrete Screw Fixing in drilled holes and then tighten.
- Silicone mastic on flange of canopy to the wall.
- To install the gallows bracket, mark the gallows on both ends 50mm in from the edge, then hold up the gallows against the canopy soffit in the desired location and pre drill and fix 90mm wood screw through the gallows in to the canopy soffit, then pre drill and fix through the other end of the gallows in to the wall using 100mm concrete screws and cover with colour matching caps and washers.
- Mastic seal the soffit, fascia and legs with the appropriate colour mastic.

Your overdoor canopy is maintenance - free, however we recommend regular cleaning with soap and water to maintain its's good looks for many years to come.

Care should be taken not to stand on the canopy as this may cause cracking or damage to the surface finish.

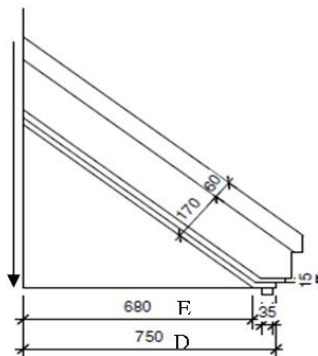

The Internet Shop trading as The Canopy Shop

T: 0345 241 7182 F: 01536 446981 E: sales@thecanopyshop.co.uk www.thecanopyshop.co.uk
Sales Office: The Canopy Shop Unit 13 Earlstrees Court, Earlstrees Industrial Estate, Corby, NN17 4AX